



HVAC Products

# SUBMITTAL

Mar 2018

**BRONZE BRAIDED FLEXIBLE CONNECTOR MPT X MPT**

PROJECT:	
CUSTOMER:	
ENGINEER:	
ARCHITECT:	

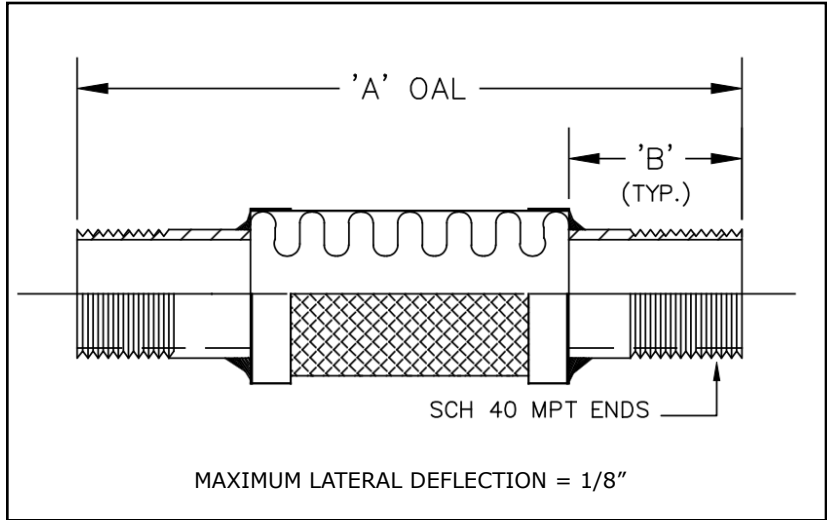

MATERIALS OF CONSTRUCTION	
HOSE:	PHOS BRONZE
BRAID:	PHOS BRONZE
END FITTINGS:	CARBON STEEL

QTY	ID # OR TAG #	HOSE DIAMETER (IN)	KEFLEX PART #	PRESSURE @ 70°F	'B' REF	'A' OAL	3D Model (.stp)
		1/4"	F002KFCBGMP	1030	1 1/2"	6"	
		3/8"	F003KFCBGMP	680	1 1/2"	6"	
		1/2"	F004KFCBGMP	700	1 1/2"	6 1/2"	
		3/4"	F006KFCBGMP	570	1 1/2"	7"	
		1"	F010KFCBGMP	460	1 3/4"	8"	
		1 1/4"	F012KFCBGMP	360	2 1/4"	8 1/2"	
		1 1/2"	F014KFCBGMP	320	2 1/4"	9"	
		2"	F020KFCBGMP	310	2 1/4"	10 1/2"	
		2 1/2"	F024KFCBGMP	270	2 1/4"	12"	
		3"	F030KFCBGMP	210	2 1/4"	12"	
		4"	F040KFCBGMP	140	2 1/4"	14 1/2"	

FOR PHOS BRONZE BRAID ABOVE 70°F	
TEMP °F	FACTOR
70	1.00
200	0.86
300	0.83
400	0.78



**WATER QUALITY**  
 NOTE: FOR SAFE WORKING PRESSURE MULTIPLY PRESSURE RATING AT 70°F BY THE APPLICABLE CORRECTION FACTOR

PROCESS MEDIA  
 NSF/ANSI/CAN 61-2022  
 NSF/ANSI/CAN 372-2022  
 MR65354

IMPORTANT LINKS	
BROCHURE:	
INSTALLATION INSTRUCTIONS:	
WEBSITE:	<a href="http://KELCOIND.COM">KELCOIND.COM</a>



**MADE IN THE USA**

**1425 LAKE AVE  
 WOODSTOCK, IL 60098  
 815-334-3600**