

BILL OF MATERIAL	
DESCRIPTION	MATERIAL
COVER & TUBE	EPDM
FLANGES, 150# DRILLING	COATED CARBON PLATE STEEL
BODY REINFORCING	NYLON
STABILIZING RING	CARBON STEEL
CONTROL RODS	GALVANIZED STEEL

MAX. TEMPERATURE: 250° F

TAG #	LOC.	DIA[IN.]	KEFLEX PART #	DESIGN PRESS @170 F	OAL	AXIAL COMP.	AXIAL EXT.	LATERAL DEFL.	ANGULAR DEFL.
		1 1/4"	F012TEE070	225	7"	2"	1 3/16"	1 3/4"	45°
		1 1/2"	F014TEE070	225	7"	2"	1 3/16"	1 3/4"	45°
		2"	F020TEE070	225	7"	2"	1 3/16"	1 3/4"	45°
		2 1/2"	F024TEE070	225	7"	2"	1 3/16"	1 3/4"	43°
		3"	F030TEE070	225	7"	2"	1 3/16"	1 3/4"	38°
		4"	F040TEE090	225	9"	2"	1 3/8"	1 9/16"	34°
		5"	F050TEE090	225	9"	2"	1 3/8"	1 9/16"	29°
		6"	F060TEE090	225	9"	2"	1 3/8"	1 9/16"	25°

DRAWN	DG	KEFLEX PRODUCTS 1425 LAKE AVENUE WOODSTOCK, ILLINOIS 60098			
DATE	9 OCT 01				
CHECKED		TITLE			
APPROVED	DG	EPDM TWIN SPHERE EXPANSION JOINT WITH 150# FLOATING FLANGES & CONTROL RODS			
SUBMITTED BY:	DATE	SIZE	FSCM NO.	DWG NO.	REV
		A	87738	SUBMITTAL DRAWING	A
CLIENT APPROVAL	DATE	JOB	SCALE	SHEET	
		EJ/SUBMITTAL	NONE	1 OF 2	

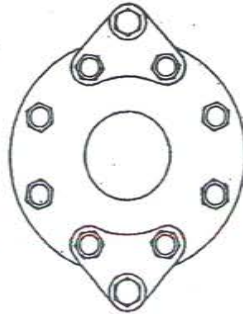
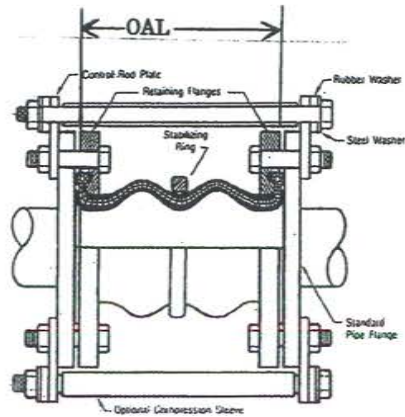

BILL OF MATERIAL	
DESCRIPTION	MATERIAL
COVER & TUBE	EPDM
FLANGES, 150# DRILLING	COATED PLATE STEEL
BODY REINFORCING	NYLON
STABILIZING RING	CARBON STEEL
CONTROL RODS	GALVANIZED STEEL

MAX. TEMPERATURE: 250° F

TAG #	LOC.	DIA[IN.]	KEFLEX PART #	DESIGN PRESS @170 F	OAL	AXIAL COMP.	AXIAL EXT.	LATERAL DEFL.	ANGULAR DEFL.
		8"	F080TEE130	225	13	2 3/8"	1 3/8"	1 3/8"	19°
		10"	F100TEE130	225	13"	2 3/8"	1 3/8"	1 3/8"	15°
		12"	F120TEE130	225	13"	2 3/8"	1 3/8"	1 3/8"	13°
		14"	F140TEE136	150	13 3/4"	1 3/4"	1 3/16"	1 3/16"	9°
		16"	F160TEE136	125	13 3/4"	1 3/4"	1 3/16"	1 3/16"	8°
		18"	F180TEE136	125	13 3/4"	1 3/4"	1 3/16"	1 3/16"	7°
		20"	F200TEE136	125	13 3/4"	1 3/4"	1 3/16"	1 3/16"	7°
		24"	F240TEE136	110	13 3/4"	1 3/4"	1 3/16"	1 3/16"	5°

DRAWN	DG	KEFLEX PRODUCTS 1425 LAKE AVENUE WOODSTOCK, ILLINOIS 60098			
DATE	9 OCT 01				
CHECKED		TITLE EPDM TWIN SPHERE EXPANSION JOINT WITH 150# FLOATING FLANGES & CONTROL RODS			
APPROVED	DG	SIZE	FSCM NO.	DWG NO.	REV
		A	87738	SUBMITTAL DRAWING	A
SUBMITTED BY:	DATE	FILE	JOB		SHEET
		SUBSETS4.DWG	EJ/SUBMITTAL		2 OF 2
CLIENT APPROVAL	DATE		SCALE	SHEET	
			NONE	2 OF 2	