



HVAC Products

SUBMITTAL

Mar 2018

GOLD SERIES -STAINLESS STEEL BRAIDED HOSE ASSEMBLY FLANGE X FLANGE

PROJECT:	
CUSTOMER:	
ENGINEER:	
ARCHITECT:	

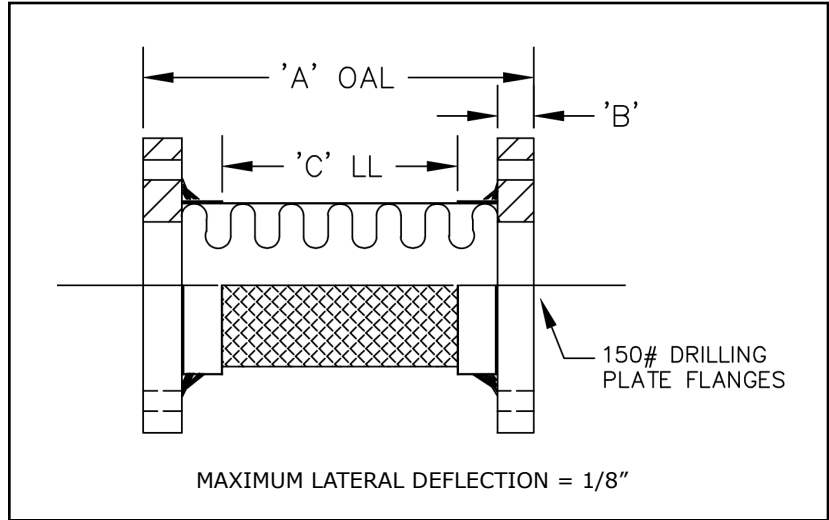

MATERIALS OF CONSTRUCTION	
HOSE:	T-321 SS
BRAID:	T-304 SS
END FITTINGS:	CARBON STEEL

QTY	ID # OR TAG #	HOSE DIAMETER (IN)	KEFLEX PART #	PRESSURE @ 70°F	'C' LL	'B' REF	'A' OAL	3D Model (.stp)
		2"	F020KSSPCF	510	5 3/4"	5/8"	9"	
		2 1/2"	F024KSSPC	380	5 3/4"	5/8"	9"	
		3"	F030KSSPC	310	5 3/4"	5/8"	9"	
		4"	F040KSSPC	230	5 3/4"	5/8"	9"	
		5"	F050KSSPC	190	7 1/2"	3/4"	11"	
		6"	F060KSSPC	165	7 1/2"	3/4"	11"	
		8"	F080KSSPC	230	8"	1"	12"	
		10"	F100KSSPC	230	9"	1"	13"	
		12"	F120KSSPC	160	10"	1"	14"	
		14"	F140KSSPC	110	10"	1"	14"	
		16"	F160KSSPC	110	10"	1"	14"	

FOR T-304 SS BRAID ABOVE 70°F	
TEMP °F	FACTOR
70	1.00
200	0.91
300	0.85
400	0.78
500	0.77
600	0.76

CLASSIFIED

WATER QUALITY
 NOTE: FOR SAFE WORKING PRESSURE MULTIPLY PRESSURE RATING AT 70°F BY THE APPLICABLE CORRECTION FACTOR

PROCESS MEDIA
 NSF/ANSI/CAN 61-2022
 NSF/ANSI/CAN 372-2022
 MH65354

IMPORTANT LINKS	
BROCHURE:	
INSTALLATION INSTRUCTIONS:	
WEBSITE:	KELCOIND.COM

MADE IN THE USA

**1425 LAKE AVE
 WOODSTOCK, IL 60098
 Ph: 815-334-3600**