

**PRE INSULATED PIPE ANCHOR**

PROJECT	
CUSTOMER	
ENGINEER	
ARCHITECT	

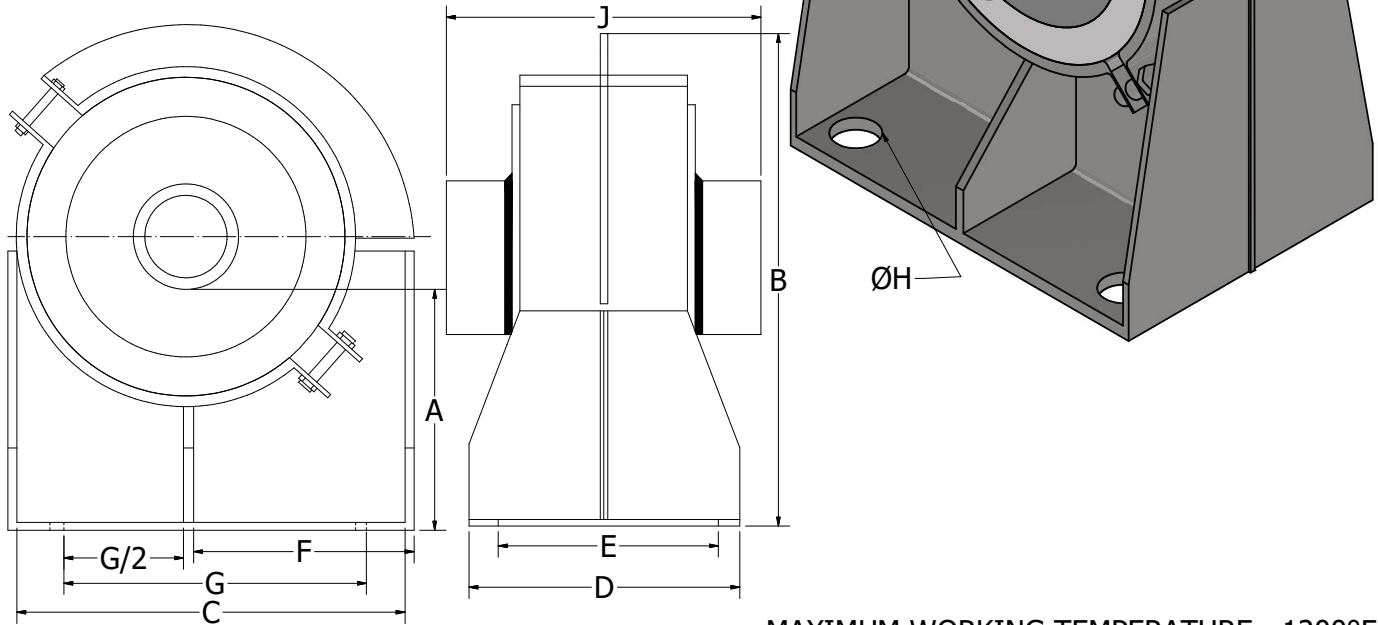

MAXIMUM WORKING TEMPERATURE : 1200°F

ANCHOR DIMENSIONS

QTY.	PART NUMBER	PIPE SIZE	A	B	C	D	E	F	G	H	J	WORKING LOADS (LBS)	INSULATION THICKNESS
	F014PIA	1-1/2"	5.56	12.13	10	8	6	5.63	5	0.63	9.88	2200	2"
	F020PIA	2"	5.31	12.13	10	8	6	5.63	5	0.63	9.88	2200	2"
	F024PIA	2-1/2"	5.63	13.68	12	8	6	6.63	7	0.63	9.88	5750	2-1/2"
	F030PIA	3"	5.31	13.68	12	8	6	6.63	7	0.63	9.88	5750	2-1/2"
	F040PIA	4"	5.31	14.63	12.75	10	8	7.06	8	0.88	10.88	7150	2-1/2"
	F050PIA	5"	5.31	15.75	14	10	8	7.69	9	0.88	10.88	9100	2-1/2"
	F060PIA	6"	5.38	17.38	16	12	10	8.69	11	0.88	11.81	12800	3"
	F080PIA	8"	6.81	21	18.75	12	10	10.06	13	1.13	11.81	17500	3"
	F100PIA	10"	7.00	24.38	22.5	20	16	12.00	15	1.63	15.75	24500	3"
	F120PIA	12"	7.19	26.50	24.5	22	18	12.94	17	1.63	16.63	30500	3"

ANCHOR MATERIAL : CARBON STEEL / STAINLESS STEEL

ALL DIMENSIONS ARE IN INCHES UNLESS SPECIFIED OTHERWISE

INSULATION INSERT : ASBESTOS FREE, XONOLITE CALCIUM SILICATE.  
(900 PSI COMPRESSIVE STRENGTH (10" & 12" - 1600 PSI)

K-FACTOR : 0.66 @ 400°F (10" & 12" - 0.70 @ 400°F).

MEETS ASTM C-533, C-585, C-795, E-72 & E-84.

FLAME SPREAD - 0, SMOKE DEVELOPED - 0.

ALL UNITS INCLUDE A VAPOR BARRIER JACKET MEETING ASTM D-744 AND PROTECTION SHIELD OF GALVANIZED / STAINLESS STEEL.

**1425 LAKE AVE**  
**WOODSTOCK, IL, 60098**  
**815-334-3600**  
[www.kelcoind.com](http://www.kelcoind.com)